



## Little Tricky Logic: Misconceptions in the Understanding of LTL

**Ben Greenman**

Sam Saarinen

Tim Nelson

Shriram Krishnamurthi

@ Brown University

**NJPLS**



**RQ.** In **what ways** is LTL tricky, and **what can we do** about it?



RQ. In **what ways** is LTL tricky, and **what can we do** about it?

+2 years of studies with researchers and students

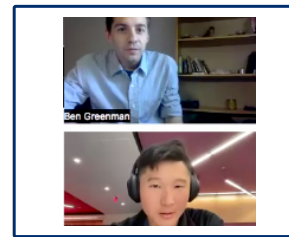
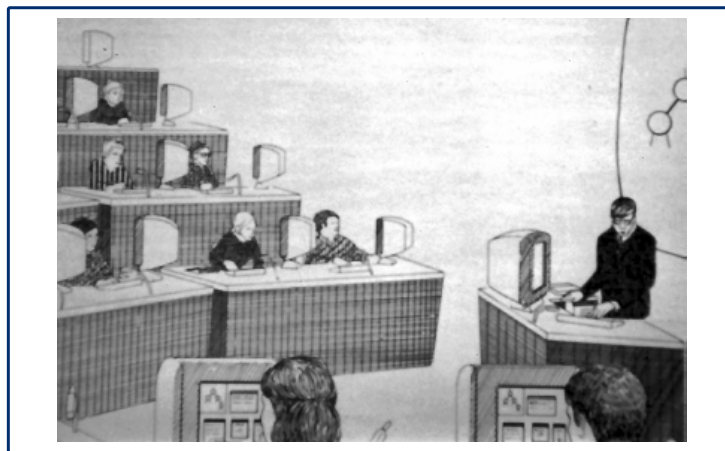



**Quiz Time!**



## Quiz Format:

one question,  
many answers,  
you decide yes/no for each

✓ ✗

Question

✓ Possible Answer 1

✗ Possible Answer 2

✓ .....

## LTl Operators:

always  
eventually  
after  
until



## **Part 1:**

Formulas vs. Traces





Q. Do the traces below satisfy the formula?  
**{eventually Red} and {eventually Green}**



Q. Do the traces below satisfy the formula?  
**{eventually Red} and {eventually Green}**

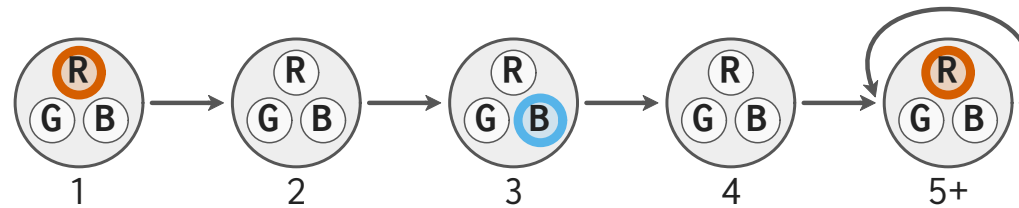



Q. Do the traces below satisfy the formula?  
**{eventually Red} and {eventually Green}**

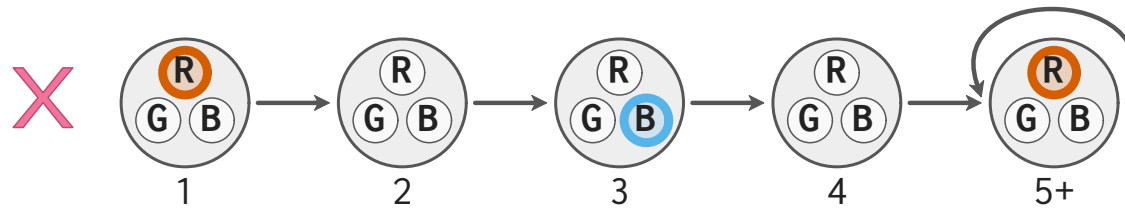

Q. Do the traces below satisfy the formula?  
**{eventually Red} and {eventually Green}**

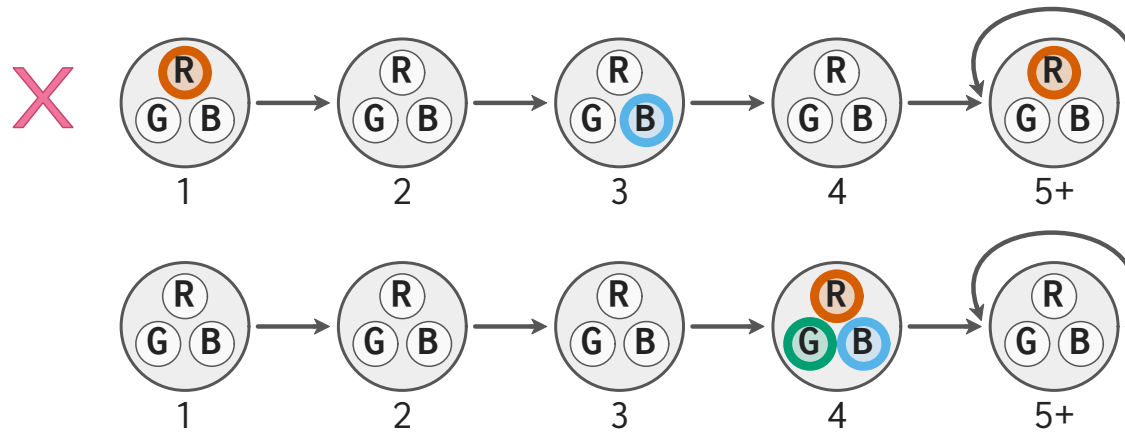

Q. Do the traces below satisfy the formula?  
**{eventually Red} and {eventually Green}**

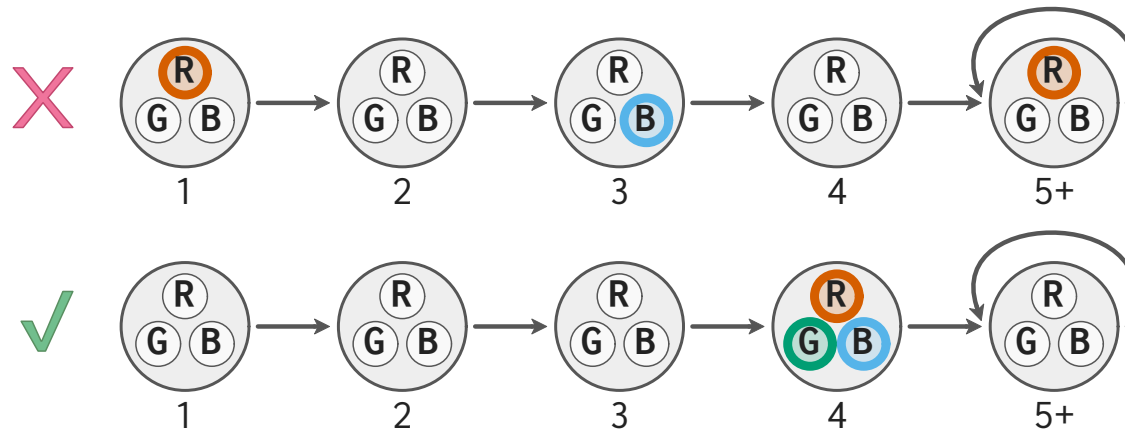

Q. Do the traces below satisfy the formula?  
**{eventually Red} and {eventually Green}**

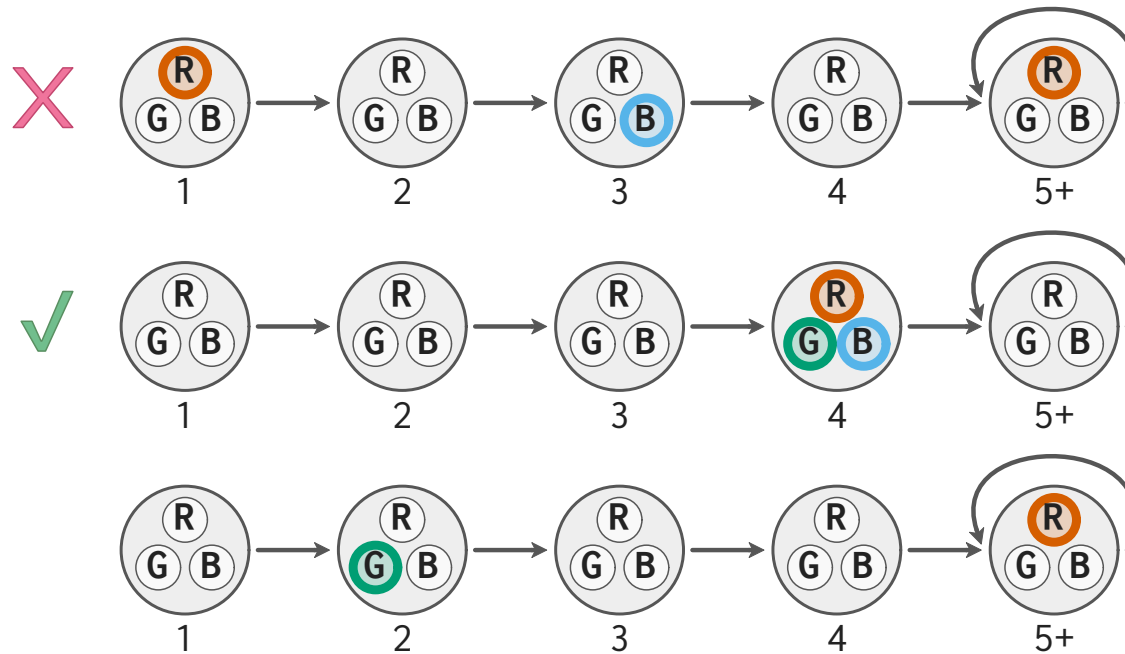

Q. Do the traces below satisfy the formula?  
**{eventually Red} and {eventually Green}**

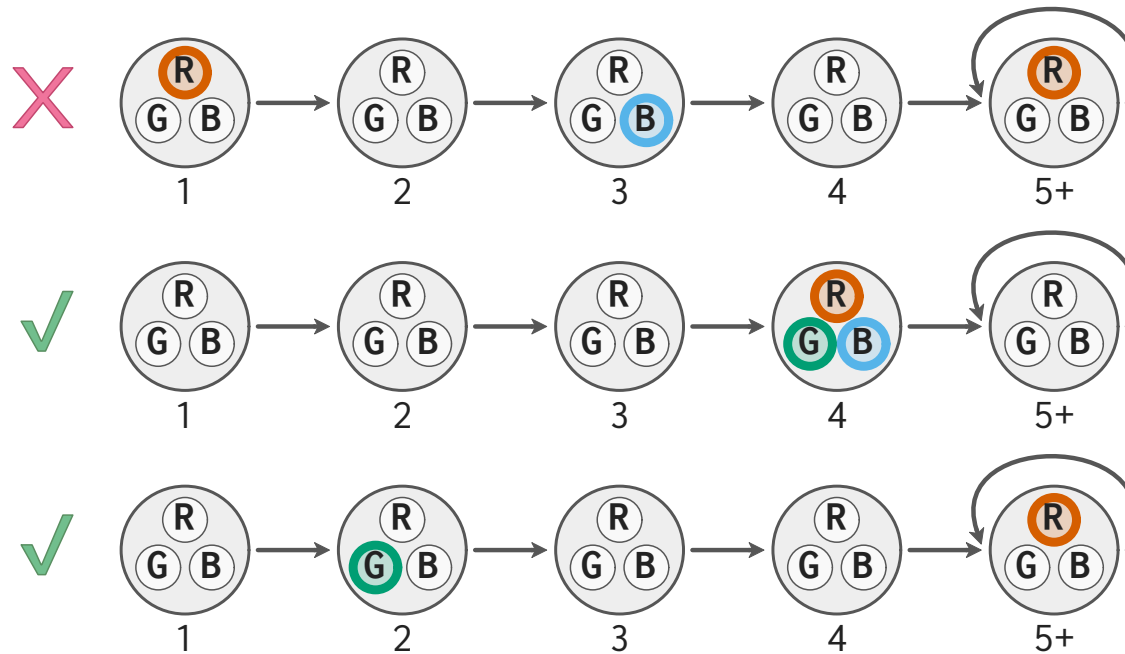

Q. Do the traces below satisfy the formula?  
**{eventually Red} and {eventually Green}**

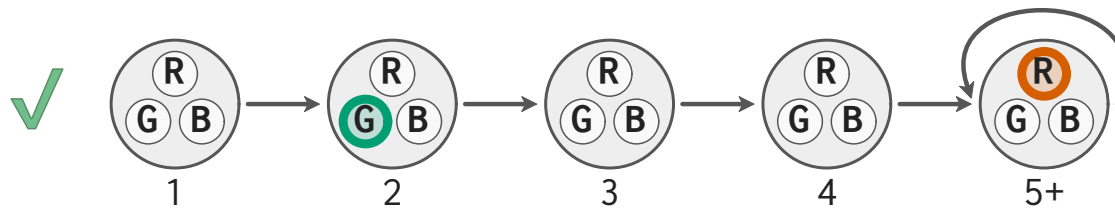

Q. Do the traces below satisfy the formula?  
**{eventually Red} and {eventually Green}**

**Not satisfied**, because Green comes before Red  
Bad Prop misconception

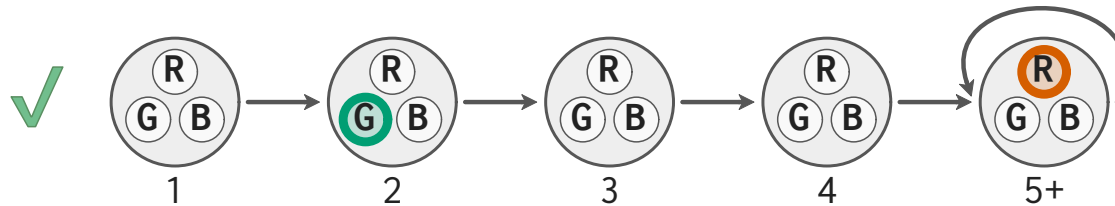



Q. Do the traces below satisfy the formula?

**Red**





Q. Do the traces below satisfy the formula?

**Red**

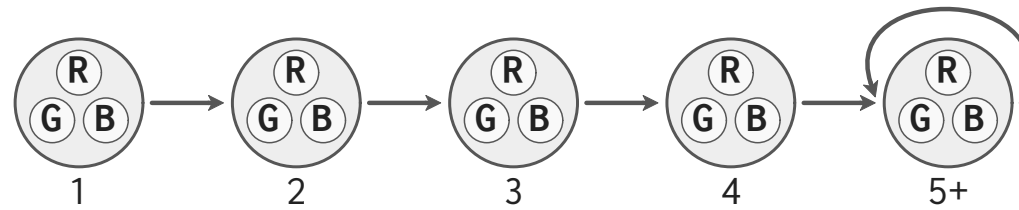

Q. Do the traces below satisfy the formula?

**Red**

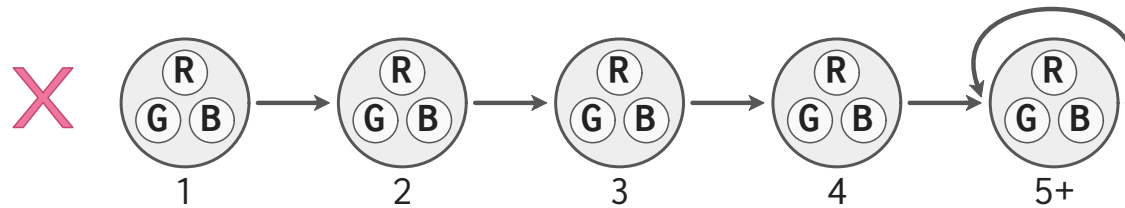

Q. Do the traces below satisfy the formula?

**Red**

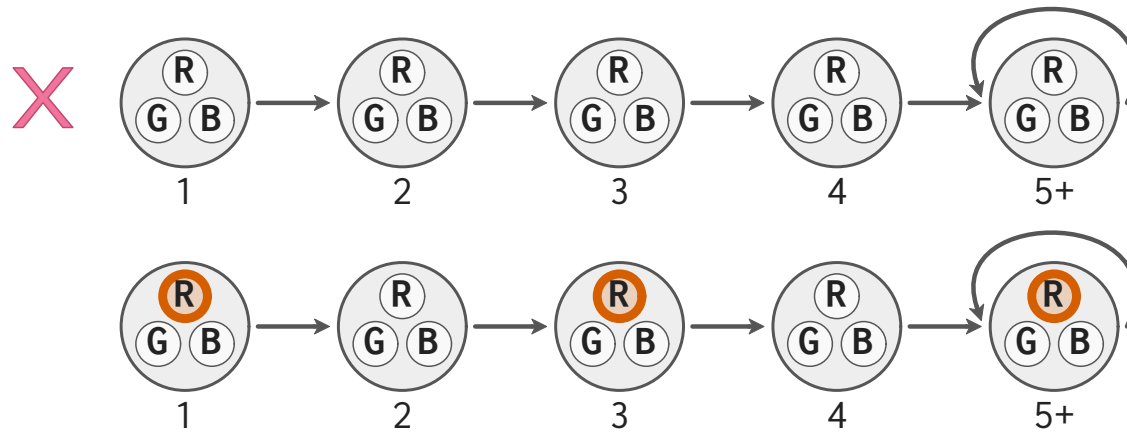

Q. Do the traces below satisfy the formula?

**Red**

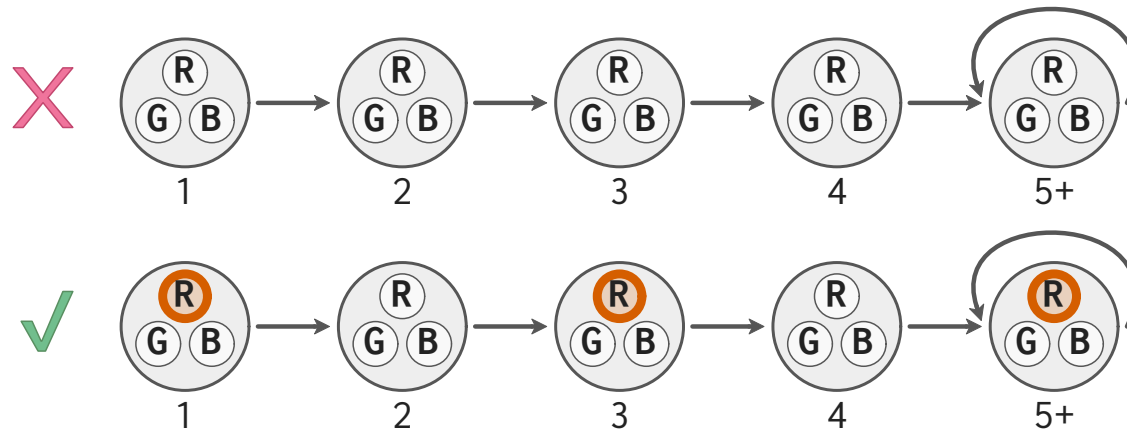

Q. Do the traces below satisfy the formula?

**Red**

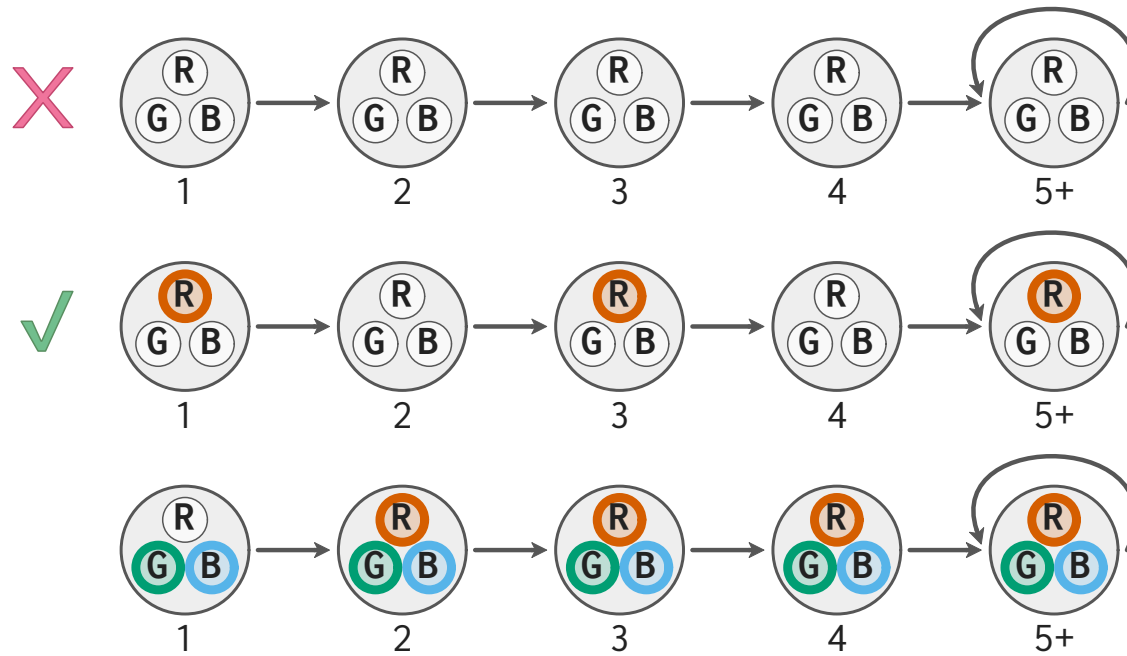

Q. Do the traces below satisfy the formula?

**Red**

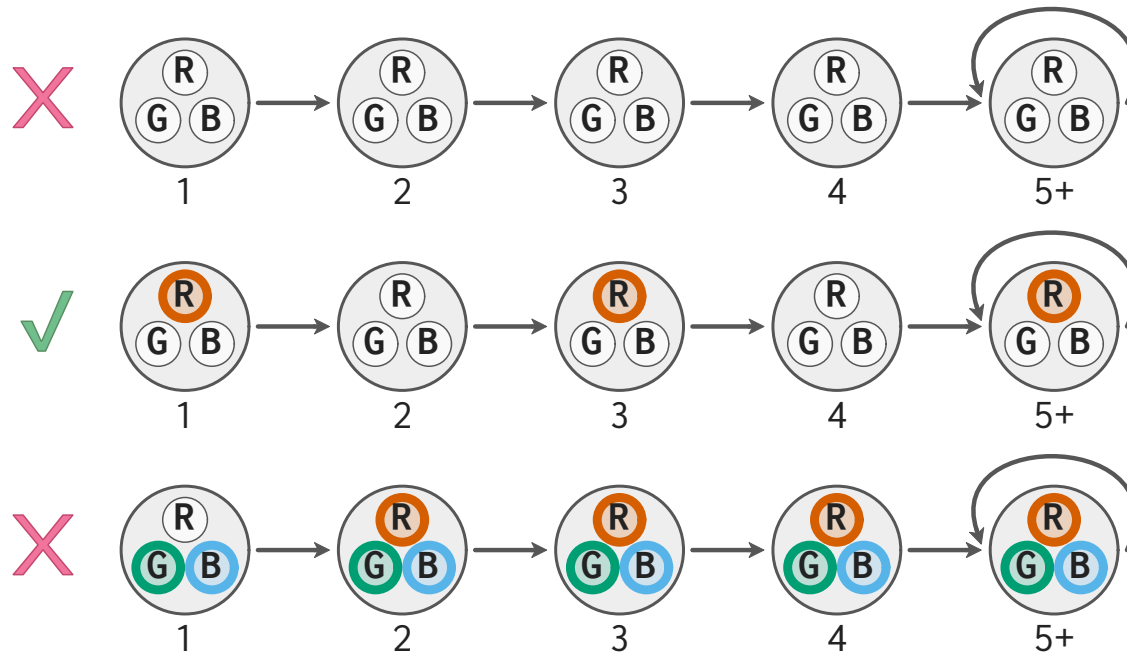

Q. Do the traces below satisfy the formula?

**Red**

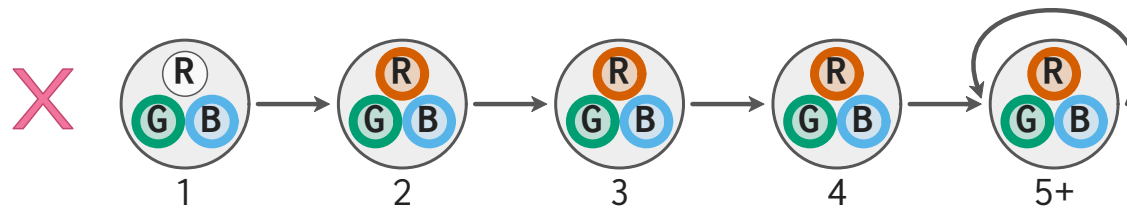

Q. Do the traces below satisfy the formula?

**Red**

**Satisfied** because Red is on at some point  
Implicit F misconception

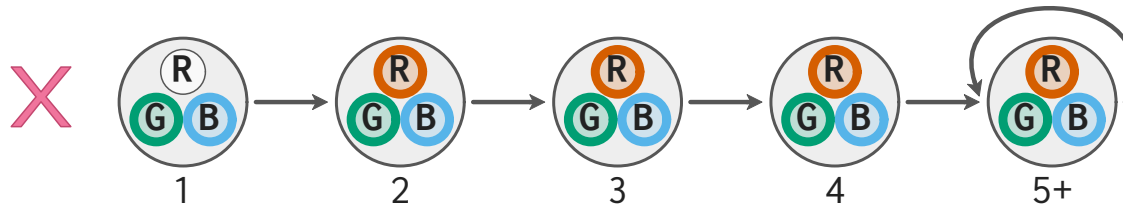





Q. Do the traces below satisfy the formula?

**Red until Blue**



Q. Do the traces below satisfy the formula?

**Red until Blue**

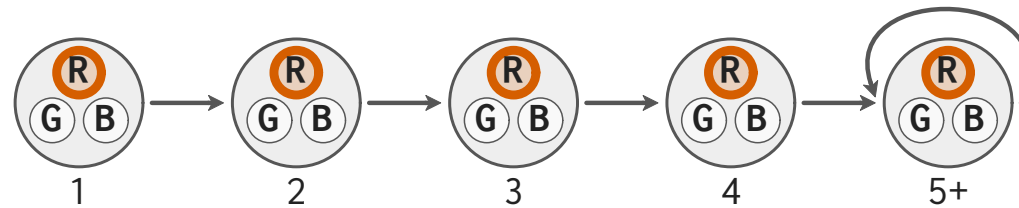

Q. Do the traces below satisfy the formula?

**Red until Blue**

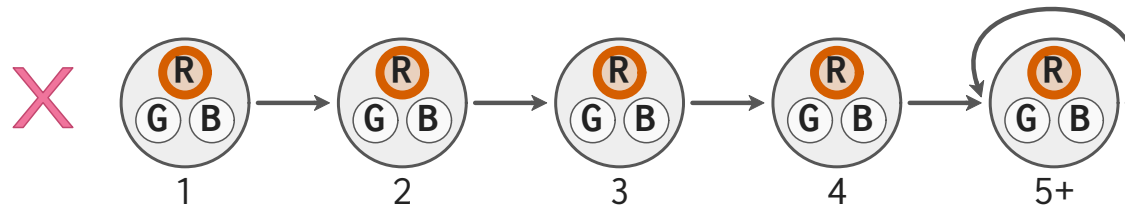

Q. Do the traces below satisfy the formula?

**Red until Blue**

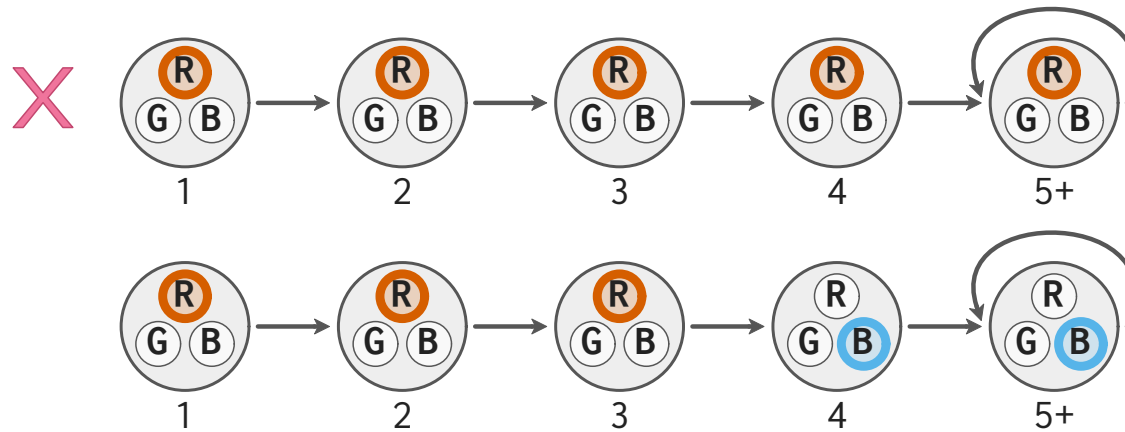

Q. Do the traces below satisfy the formula?

**Red until Blue**

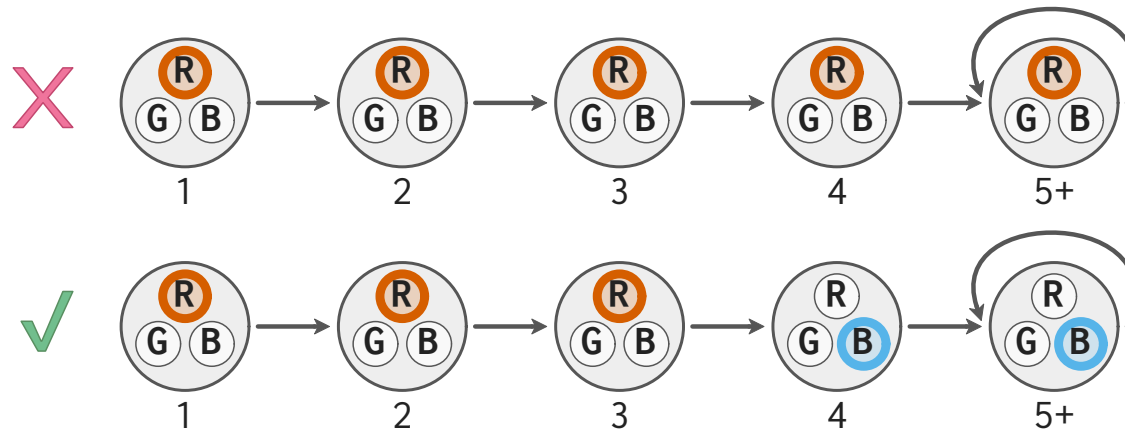

Q. Do the traces below satisfy the formula?

**Red until Blue**

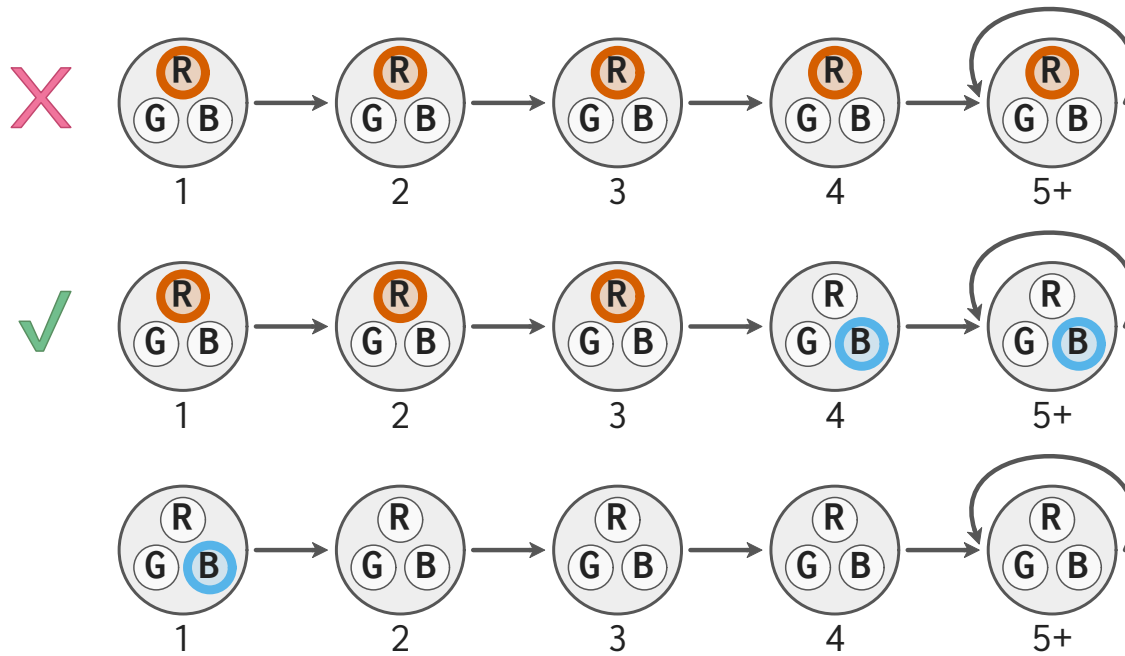

Q. Do the traces below satisfy the formula?

**Red until Blue**

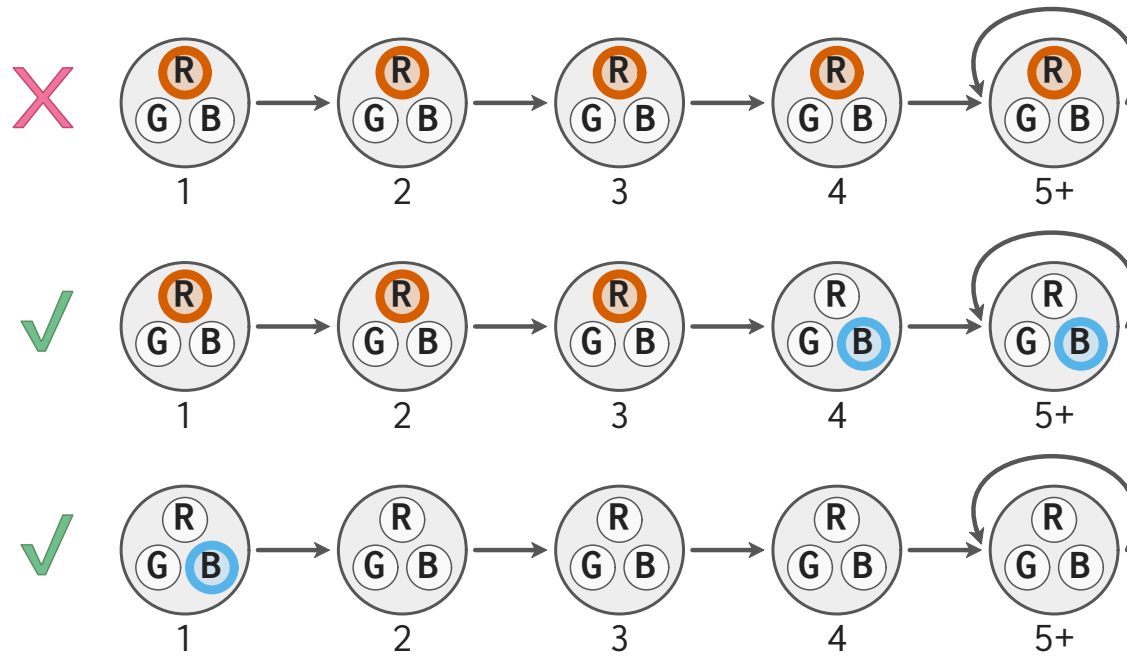

Q. Do the traces below satisfy the formula?

**Red until Blue**

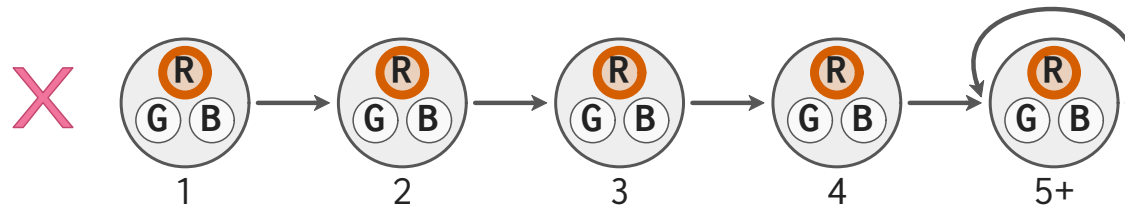



Q. Do the traces below satisfy the formula?

**Red until Blue**

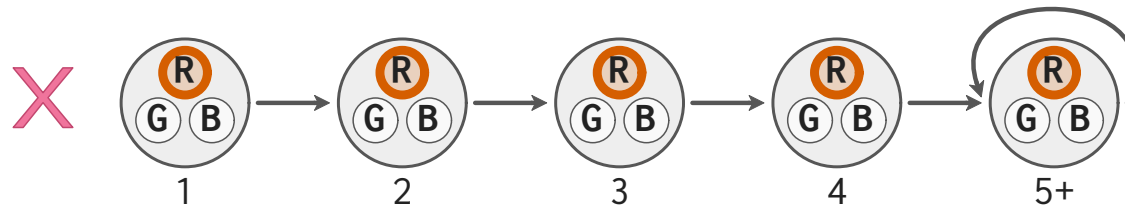

**Satisfied** because Blue may stay off

*Even among researchers!*

Weak U misconception



## **Part 2:**

LTL to English





Q. Translate to English  
**{Red until Blue} and {always Red}**



Q. Translate to English  
**{Red until Blue} and {always Red}**

"Red is always on"

Q. Translate to English  
**{Red until Blue} and {always Red}**

**X** "Red is always on"

Q. Translate to English  
**{Red until Blue} and {always Red}**

**X** "Red is always on"

"Red is always on and Blue is eventually on"

Q. Translate to English  
**{Red until Blue} and {always Red}**

**X** "Red is always on"

**✓** "Red is always on and Blue is eventually on"

Q. Translate to English  
**{Red until Blue} and {always Red}**

**X** "Red is always on"

**✓** "Red is always on and Blue is eventually on"

"This statement can never be satisfied"



Q. Translate to English  
**{Red until Blue} and {always Red}**

**X** "Red is always on"

**✓** "Red is always on and Blue is eventually on"

**X** "This statement can never be satisfied"

Q. Translate to English  
**{Red until Blue} and {always Red}**

**X** "This statement can never be satisfied"

Q. Translate to English  
**{Red until Blue} and {always Red}**

When Blue turns on, Red **must** be off  
Exclusive U misconception

**X** "This statement can never be satisfied"



Q. Translate to English  
**{eventually Red} implies {always Blue}**



Q. Translate to English  
**{eventually Red} implies {always Blue}**

"if Red is ever on, then Blue is always on"

Q. Translate to English  
**{eventually Red} implies {always Blue}**

✓ "if Red is ever on, then Blue is always on"

Q. Translate to English  
**{eventually Red} implies {always Blue}**

✓ "if Red is ever on, then Blue is always on"

"Red is on at some point, after which Blue is on"

Q. Translate to English  
**{eventually Red} implies {always Blue}**

✓ "if Red is ever on, then Blue is always on"

✗ "Red is on at some point, after which Blue is on"



Q. Translate to English  
**{eventually Red} implies {always Blue}**

**X** "Red is on at some point, after which Blue is on"

Q. Translate to English  
**{eventually Red} implies {always Blue}**

Red **will** turn on  
Bad Prop misconception

**X** "Red is on at some point, after which Blue is on"



## **Part 3:**

English to LTL





Q. Translate to LTL

**The Red light is on in exactly one state, but not necessarily the first state**





Q. Translate to LTL

**The Red light is on in exactly one state, but not necessarily the first state**

Impossible!



Q. Translate to LTL

**The Red light is on in exactly one state, but not necessarily the first state**

**X** Impossible!

Q. Translate to LTL

**The Red light is on in exactly one state, but not necessarily the first state**

**X** Impossible!

`{eventually Red} and {always {Red => always !Red}}`

Q. Translate to LTL

**The Red light is on in exactly one state, but not necessarily the first state**

**X** Impossible!

**X** {eventually Red} and {always {Red => always !Red}}



Q. Translate to LTL

**The Red light is on in exactly one state, but not necessarily the first state**

**X** Impossible!

**X** {eventually Red} and {always {Red => always !Red}}

{eventually Red} and {always {Red => after {always !Red}}}

Q. Translate to LTL

**The Red light is on in exactly one state, but not necessarily the first state**

**X** Impossible!

**X** {eventually Red} and {always {Red => always !Red}}

**✓** {eventually Red} and {always {Red => after {always !Red}}}

Q. Translate to LTL

**The Red light is on in exactly one state, but not necessarily the first state**

**X** {eventually Red} and {always {Red => always !Red}}

Q. Translate to LTL

**The Red light is on in exactly one state, but not necessarily the first state**

An implication constrains the **next state**

Bad State Index misconception

**X** {eventually Red} and {always {Red => always !Red}}



**All Done!**



Simple formulas, yet  
**subtle issues** and **expert blind spots**



## Quiz Q's Based on 3 Instruments

- LTL to English
- English to LTL
- Trace Satisfaction

**Example Question:** Is the formula  
always ( Engine or Light )  
satisfied by this trace?

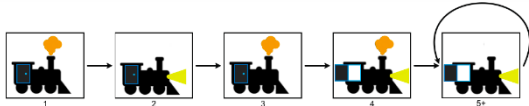

**Example Answer:** Yes, because either the engine (smoke) or the headlight is on in each state.

Does the example make sense to you?\*

Yes

No (please explain)

**Q:** Is the formula  
( Red ) until ( Blue )  
satisfied by this trace?\*

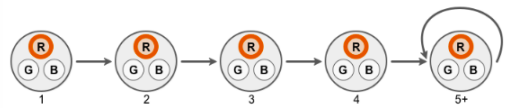

Yes

No

[cs.brown.edu/~bgreenma/ltl-instruments.pdf](http://cs.brown.edu/~bgreenma/ltl-instruments.pdf)

## Code Book for Analysis

Bad Prop

Implicit F

Bad State Index

Implicit G

Bad State Quantification

Other Implicit

Exclusive U

Weak U

To appear in **Programming 7.2**



# Software: Quizius

Class-sourcing to discover misconceptions

## 1. Answer Top Q's

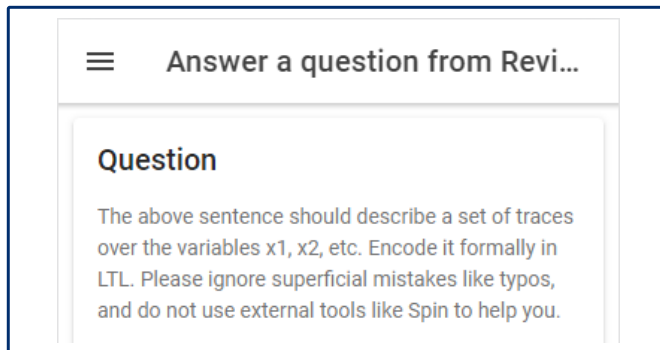

☰ Answer a question from Revi...

**Question**

The above sentence should describe a set of traces over the variables  $x_1$ ,  $x_2$ , etc. Encode it formally in LTL. Please ignore superficial mistakes like typos, and do not use external tools like Spin to help you.

## 2. Submit New Q's

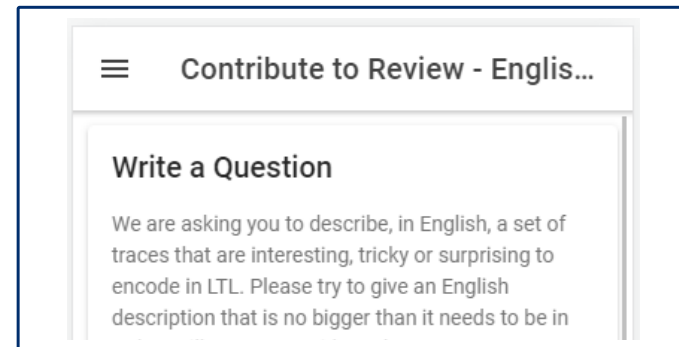

☰ Contribute to Review - Englis...

**Write a Question**

We are asking you to describe, in English, a set of traces that are interesting, tricky or surprising to encode in LTL. Please try to give an English description that is no bigger than it needs to be in



**What Next?**



# What Next?

## 1. Teach Better

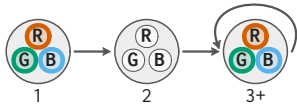

our instruments can help!

# What Next?

## 1. Teach Better

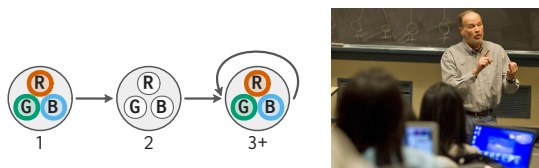

our instruments can help!

... but learners are everywhere  
not just in classrooms

**amazon**

**Meta**

**NETFLIX**

# What Next?

## 1. Teach Better

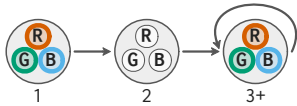

our instruments can help!

## What Next?

### 1. Teach Better

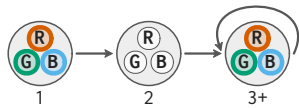

our instruments can help!

### 2. Build Tools

guard against misconceptions

## What Next?

### 1. Teach Better

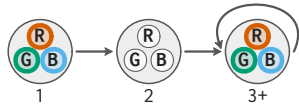

our instruments can help!

### 2. Build Tools

guard against misconceptions

### 3. Design Logics

**Alloy 6**

**Electrum**

our findings have inspired changes



**Thank You!**

benjamin.l.greenman@gmail.com

